

# 2TN

## TECLE ELÉCTRICO C/GANCHO - C/TROLLEY DOBLE VELOCIDAD

**TXX**  
JAPANESE INDUSTRY

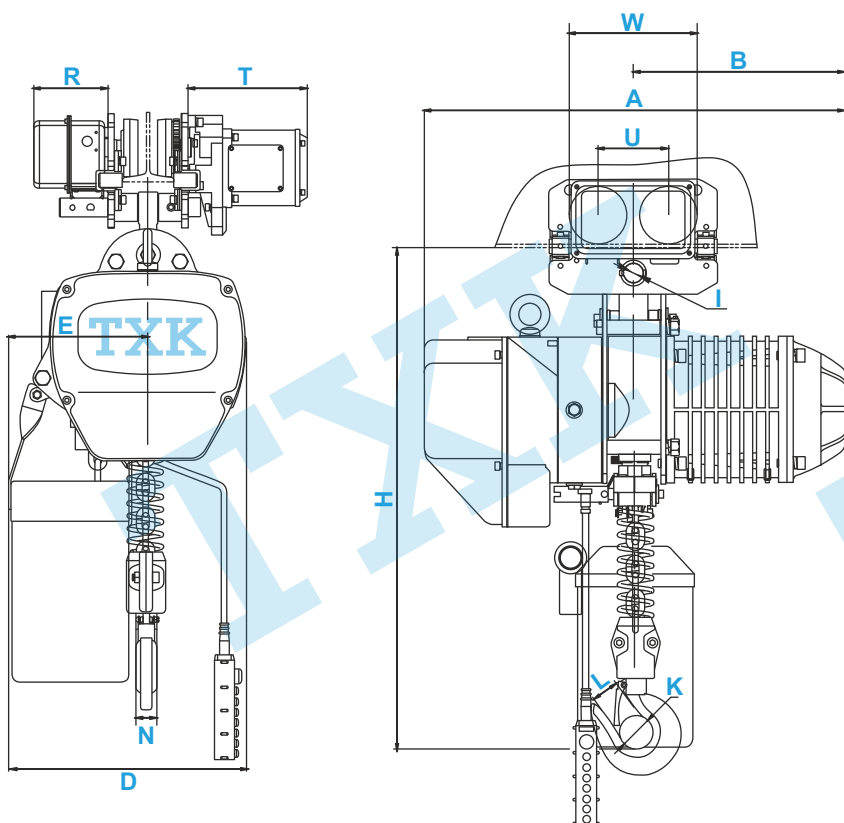

### ● Datos Técnicos

Tipo	Capacidad (TN)	Izaje (m)	Motor de Tecla					Motor de Trolley					
			Velocidad (m/min)	Potencia (kw)	Rpm	Fases	Voltaje (V)	Velocidad (m/min)	Potencia (kw)	Fases	Rpm	Voltaje (V)	Ancho de Ala Viga (mm)
SSDHL02 - 010	2	3	2.7/8.2	1.0/3.0 kw	930/2830	3	220/380/440	25.2	0.75 kw	3	1440	220/380/440	75 - 230

### ● Dimensiones del Equipo

Tipo	Capacidad (TN)	Dimensiones (mm)													
		H	A	B	D	E	I	K	L	N	W	U	R	T	Cadena
SSDHL02 - 010	2	770	615	295	430	265	φ36	φ49	40	30	237	127	142	231	φ10.0